

Planung und Montage

Beschlag zum Schieben von Holz-, Metall- oder Leichtmetall-Schiebeläden bis 60 kg Gewicht.

Planification et montage

Ferrure pour faire coulisser des volets coulissants en bois, métal ou métal léger jusqu'à un poids de 60 kg.

Planning and installation

Hardware system for wood, metal or aluminium sliding shutters with a panel weight up to 60 kg (132 lbs.).

Pianificazione e montaggio

Ferramenta per lo scorrimento di scuri scorrevoli in legno, metallo o alluminio fino a 60 kg.

Planificación y montaje

Sistema de herrajes para postigos deslizantes de madera, metal o aluminio, hasta un peso de 60 kg.

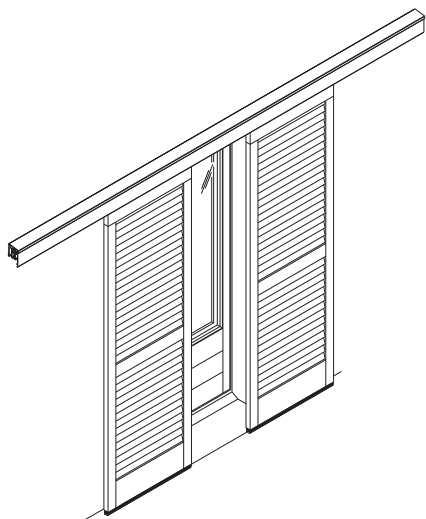

Achtung: mit neuer Laufschiene andere Einbauhöhe.

Attention: avec nouveau rail de roulement autre hauteur d'encastrement.

Caution: with new top track other installation height.

Attenzione: con nuovo binario superiore altezza di montaggio diversa.

Atención: con nuevo riel de rodadura se tiene otra altura de montaje.

■ Hawa-Teile ■ Eléments Hawa ■ Hawa components ■ Componenti Hawa ■ Componentes Hawa

Metric specifications are exact - Inches are approximate

Diese Zeichnung ist Eigentum der Hawa AG und darf weder verwertet, vervielfältigt noch Dritten zugänglich gemacht werden. Alle unsere Katalog-Zeichnungen sowie die speziellen Einbauzeichnungen im Massstab 1:1 usw. stellen Beispiele zum Einbau unserer Beschläge dar. Irgendwelche Ansprüche aus der Verwendung dieser Unterlagen können durch den Kunden nicht abgeleitet werden. Für bau-/projektbezogene, konstruktive Details wird keine Verantwortung übernommen.

Ce plan est la propriété de Hawa AG. Il ne peut être utilisé à titre lucratif, ni photocopié ou transmis à un tiers. Tous les plans publiés dans les catalogues, les plans de montage spéciaux à l'échelle 1:1 etc. représentent des exemples de montage de nos ferrures. Le client ne peut tirer des droits quelconques en utilisant de tels documents. Pour des détails constructifs touchant aux projets ou aux sites, toute responsabilités est déclinée.

This drawing remains the property of Hawa AG and may not be sold, reproduced or made available to third parties. All of our catalogue drawings and special full scale installation drawings etc. represent installations using our hardware and fittings. No claims on the part of the customers can be considered which arise in connection with the use of these documents. For site or project-related design details any liability is declined.

Questo disegno è proprietà di Hawa AG e non può essere usato a scopo di lucro, riprodotto e reso accessibile a terzi. Tutti i nostri disegni del catalogo nonché i particolari disegni di montaggio in scala 1:1 ecc. rappresentano esempi per il montaggio delle nostre ferramenta. Eventuali rivendicazioni a seguito dell'utilizzo di questa documentazione non possono essere evidenziate da parte del cliente. Non assumiamo nessuna responsabilità per dettagli costruttivi che riguardano qualsiasi costruzione o progetto.

Este documento es propiedad de la empresa Hawa AG. Se excluye la venta y reproducción, al igual que el acceso a terceras personas. Los planos contenidos en nuestros catálogos, al igual que los planos especiales de montaje a escala 1:1 etc. representan ejemplos para el montaje de nuestros herrajes. Su uso no implica la deducción de derechos, cualquiera sea su naturaleza, por parte del cliente. No asumimos ninguna responsabilidad por los detalles constructivos relativos a la construcción o proyectos.

HAWA - Frontslide 60/A

Patente/Brevets/Patents/
Brevetti/Patentados

<h1>19872</h1>	<h1>b</h1>	Gezeichnet/Dessiné/Drafted/Disegnato/Dibujado 05.2004 / STJ	Internationale Schutzrechte Änderungen vorbehalten Droits internationaux déposés Sous réserve de modifications Swiss and foreign patents Design subject to modification Diritti protettivi internazionali Con riserva di apportare modifiche Derechos internacionales protegidos Planos sujetos a modificaciones
		Änderung/Modification/Modification/Modifica/Modificación 05.2007 / STJ	
		Ersatz/Remplace/Replaces/Sostituisce/Reemplaza 19872a	
		Visum/Visa/Visa/Visto/Visado 01.2008 / FME	



Hawa AG CH-8932 Mettmenstetten Tel. +41 44 767 91 91 Fax +41 44 767 91 78
www.hawa.ch

a) 26.01.06 / FME (3534)
b) 23.05.07 / FME (3872)

Deutsch

HAWA-Frontslide 60/A

Maximales Gewicht pro Schiebeladen 60 kg
Minimale Breite pro Schiebeladen 400 mm
Schiebeladendicke 28–40 mm

Anforderungen an das Montagepersonal

Die Montage darf nur durch Personal mit entsprechender handwerklicher Ausbildung ausgeführt werden.

Das Montagepersonal ist erst dann autorisiert die in der Montageanleitung beschriebenen Arbeiten auszuführen, wenn es die Montageanleitung gelesen und verstanden hat.

Français

HAWA-Frontslide 60/A

Poids maximum par volet coulissant 60 kg
Largeur minimum par volet coulissant 400 mm
Épaisseur du volet coulissant 28–40 mm

Exigences posées au personnel de montage

Le montage du système ne peut être réalisé que par des personnes ayant reçu une formation pratique appropriée.

Par ailleurs, le personnel responsable du montage est autorisé à exécuter les opérations décrites dans la présente instruction de montage uniquement après avoir lu et compris l'instruction de montage et les prescriptions de sécurité qu'il contient.

English

HAWA-Frontslide 60/A

Maximum weight per sliding shutter 60 kg (132 lbs.)
Minimum width per sliding shutter 400 mm (1'3 $\frac{3}{4}$ ")
Sliding shutter thickness 28–40 mm (1 $\frac{1}{8}$ "–1 $\frac{19}{32}$ ")

Assembly personnel requirements

Assembly work may only be performed by personnel with appropriate technical training. In addition hereto, assembly personnel are only then authorised to carry out the work described in these instructions once they have read and understood the assembly instructions and relevant safety regulations.

Italiano

HAWA-Frontslide 60/A

Peso scuro 60 kg max
Larghezza scuro 400 mm min
Spessore scuro 28–40 mm

Requisiti dei montatori

Il montaggio deve essere eseguito esclusivamente da personale con adeguata formazione. Inoltre, i montatori sono autorizzati ad eseguire i lavori di montaggio descritti solo dopo aver letto e acquisito le relative istruzioni e prescrizioni per la sicurezza.

Español

HAWA-Frontslide 60/A

Peso máximo por postigo deslizante 60 kg
Ancho mínimo por postigo deslizante 400 mm
Espesor del postigo deslizante 28–40 mm

Requerimientos al personal de montaje

El montaje debe ser realizado únicamente por personas perfectamente capacitadas y con la formación adecuada.

En adición a esto, el personal que lleve a cabo el montaje debe ser solamente autorizado a realizar el trabajo descrito en estas instrucciones una vez que hubieran leído y comprendido las instrucciones de montaje y las indicaciones relevantes sobre seguridad.

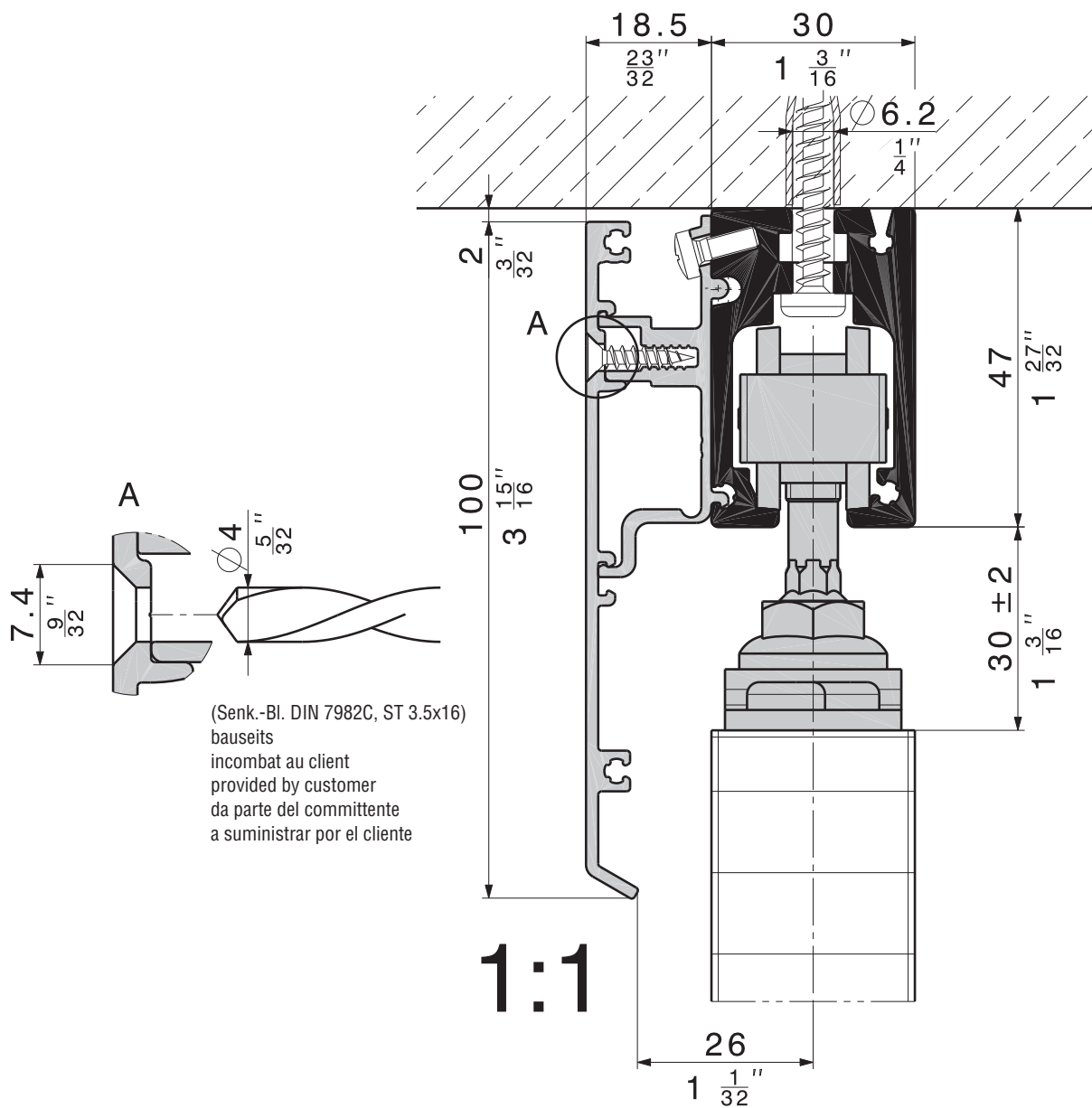

Technische Änderungen vorbehalten
Sous réserve de modifications techniques
Subject to modification

Con riserva di apportare modifiche tecniche
Bajo reserva de modificaciones técnicas

Montage-Varianten
Variantes de montage
Assembly options
Varianti di montaggio
Variantes de montaje

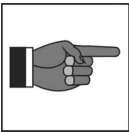
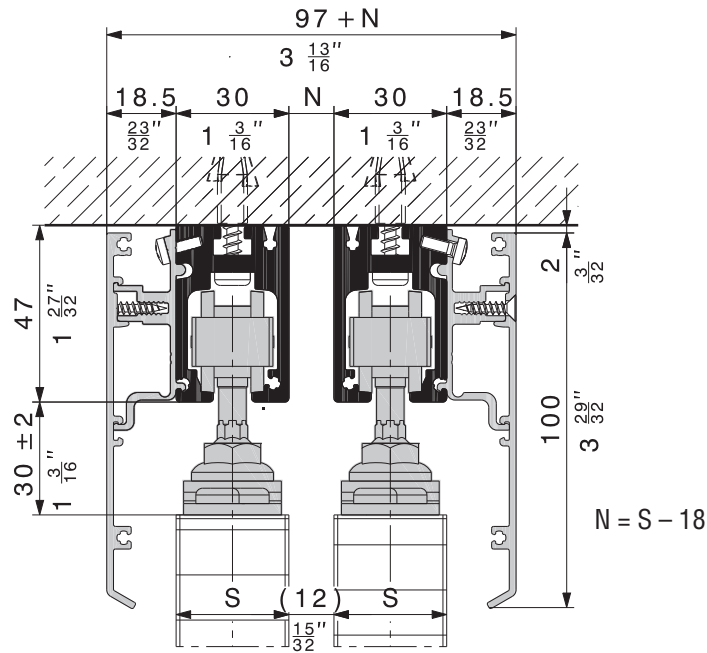

Bei der Profilmontage müssen die unterschiedlichen Längenausdehnungen der Materialien berücksichtigt werden.
 Lors du montage des profils, il faut tenir compte de la dilatation longitudinale variable des différents matériaux.
 Remember to take differences in linear expansion for the different materials into account when fitting profiles.
 Nel montaggio dei profili tener conto delle diverse dilatazioni lineari dei materiali.
 Al montar los perfiles deberá tener en cuenta la dilatación longitudinal de los diferentes materiales utilizados.

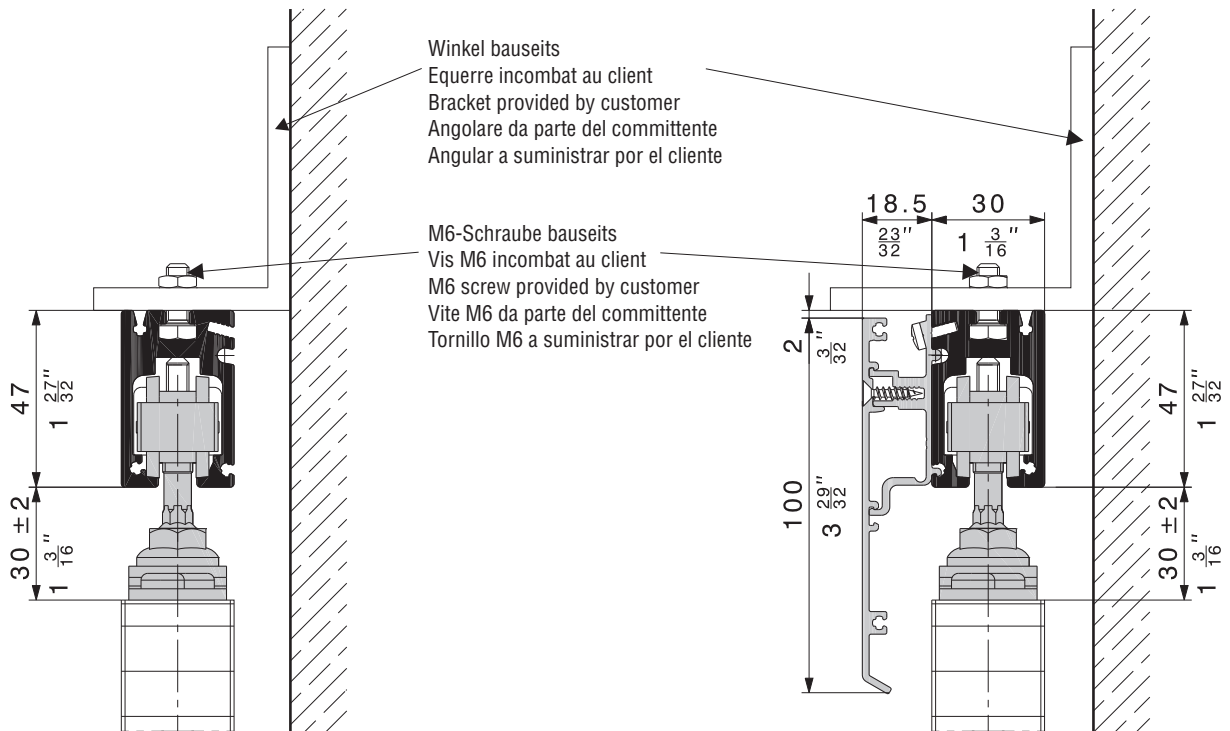

Technische Änderungen vorbehalten
 Sous réserve de modifications techniques
 Subject to modification

Con riserva di apportare modifiche tecniche
 Bajo reserva de modificaciones técnicas

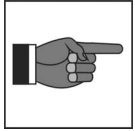

Die Auflage für die Winkeltragprofile muss plan sein.
 Le support des profils porteurs en équerre doit être plan.
 Make sure the mounting surface for the angle brackets is completely plane.
 L'appoggio dei profili portanti angolari deve essere in piano.
 La base de los perfiles angular debe ser lisa.

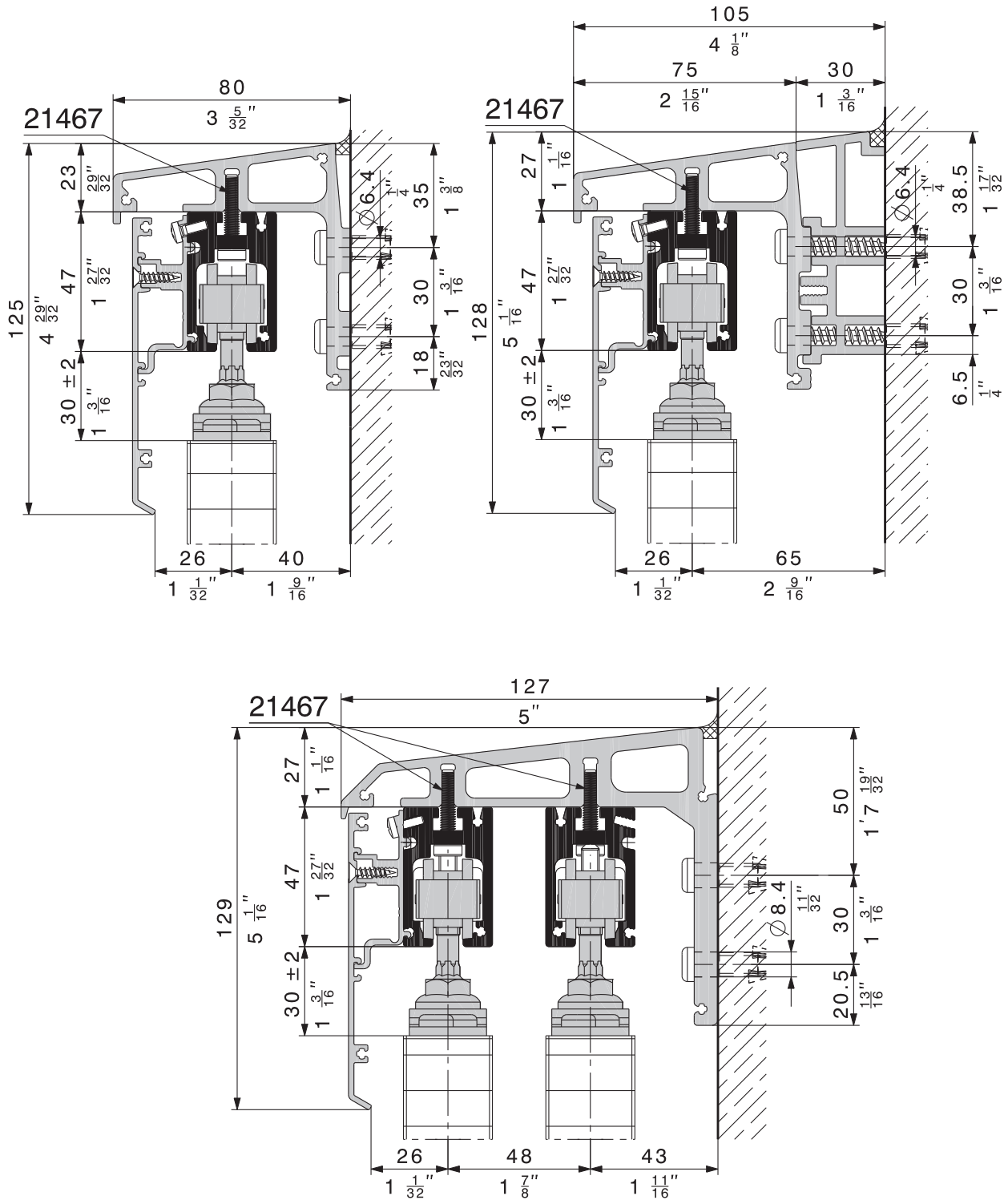

Technische Änderungen vorbehalten
 Sous réserve de modifications techniques
 Subject to modification

Con riserva di apportare modifiche tecniche
 Bajo reserva de modificaciones técnicas

Montage der Laufschiene
Montage des rails de roulement
Mounting of top tracks
Montaggio delle rotaie
Montaje de los rieles de rodadura

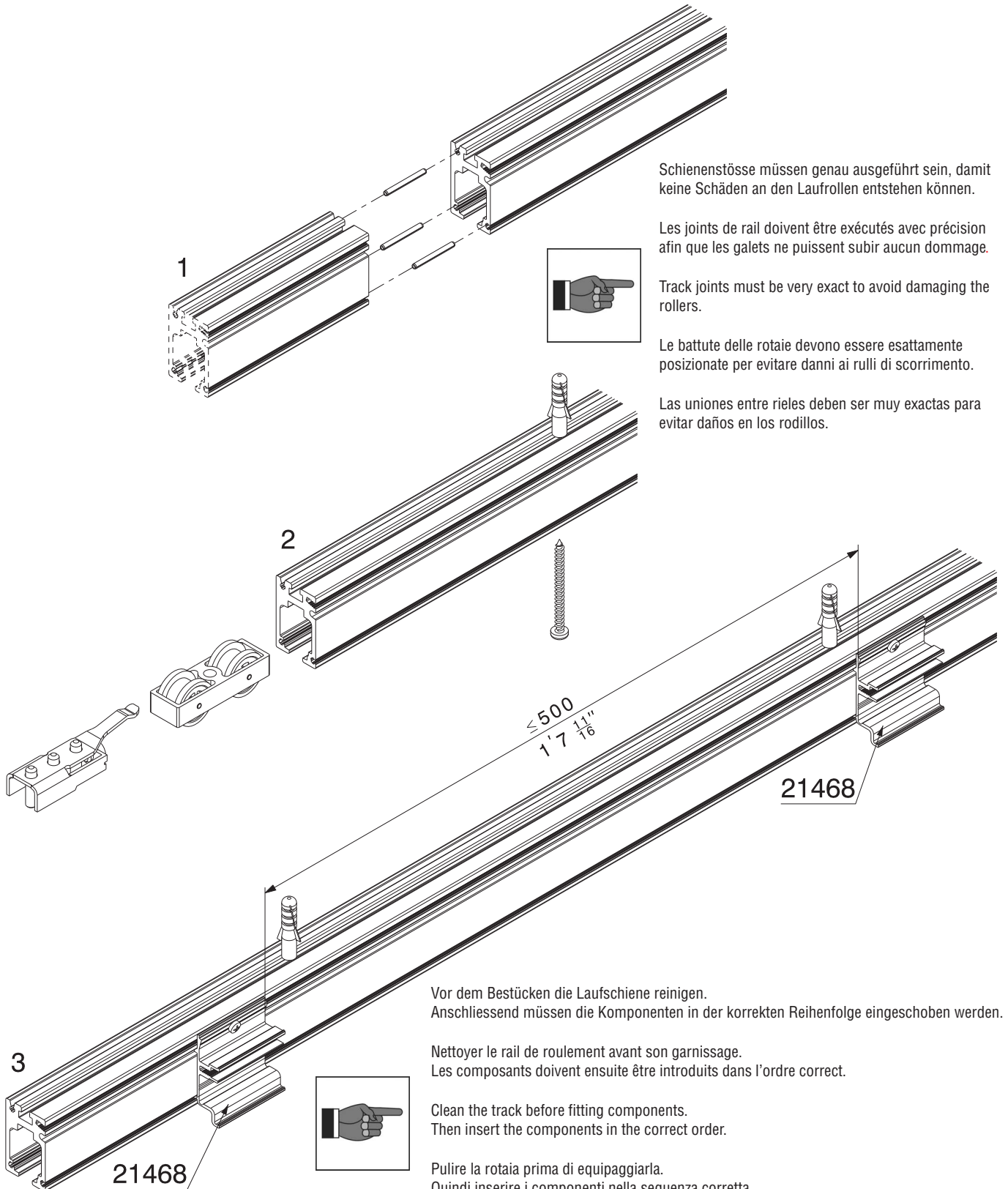

Schienenstösse müssen genau ausgeführt sein, damit keine Schäden an den Laufrollen entstehen können.

Les joints de rail doivent être exécutés avec précision afin que les galets ne puissent subir aucun dommage.

Track joints must be very exact to avoid damaging the rollers.

Le battute delle rotaie devono essere esattamente posizionate per evitare danni ai rulli di scorrimento.

Las uniones entre rieles deben ser muy exactas para evitar daños en los rodillos.

Vor dem Bestücken die Laufschiene reinigen.
Anschliessend müssen die Komponenten in der korrekten Reihenfolge eingeschoben werden.

Nettoyer le rail de roulement avant son garnissage.
Les composants doivent ensuite être introduits dans l'ordre correct.

Clean the track before fitting components.
Then insert the components in the correct order.

Pulire la rotaia prima di equipaggiarla.
Quindi inserire i componenti nella sequenza corretta.

Limpiar el riel antes de colocar los componentes.
Luego colocar los componentes en el orden correcto.

Montage Schiebeladen und Verblendung
Montage Volet coulissant et cache
Assembling the sliding shutters and covers
Montaggio scuro e rivestimento
Montaje de postigos deslizantes y coberturas

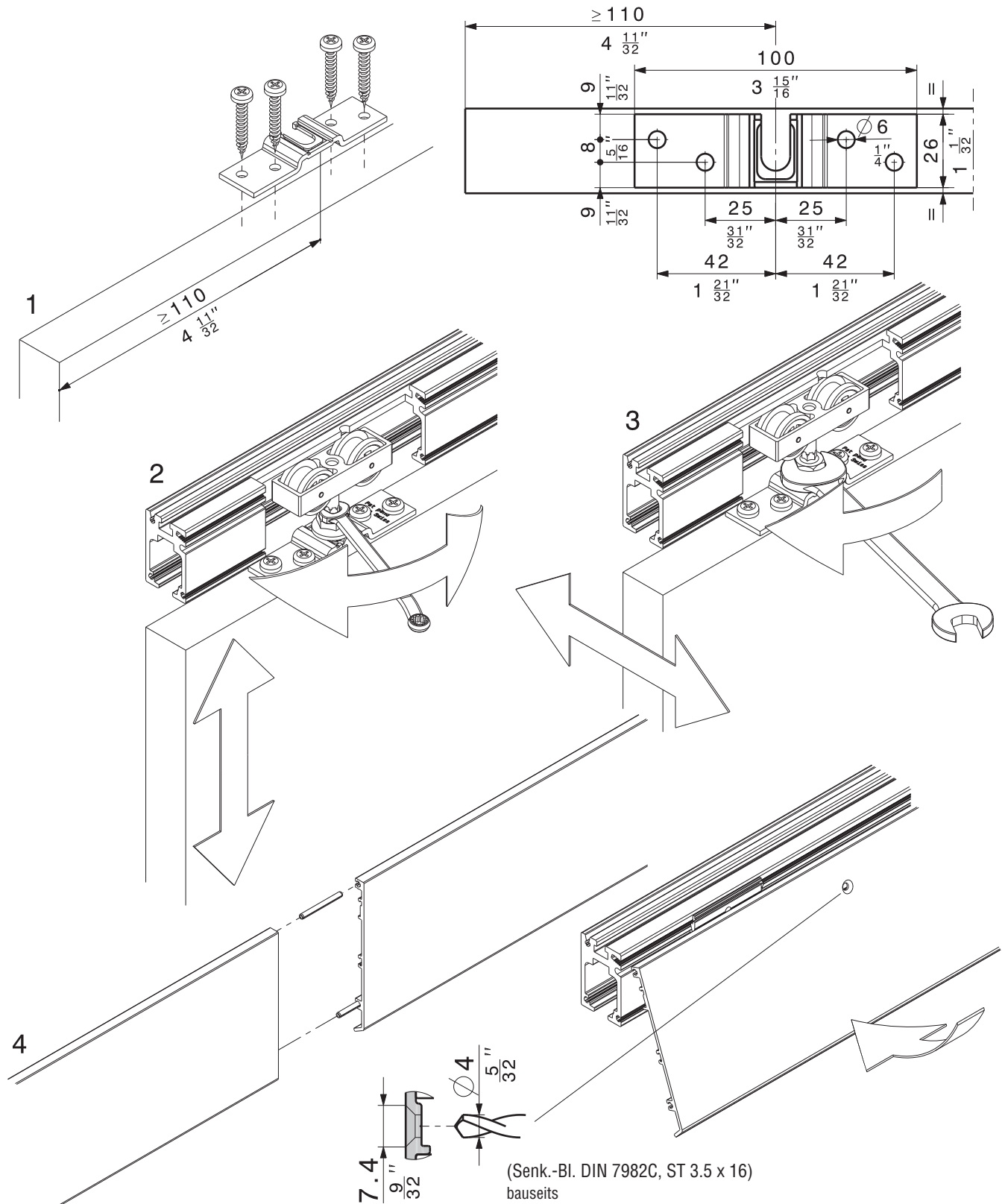

Blende mit Schrauben sichern.
 Fixer le cache avec des vis.
 Secure cover with screws.
 Fissare la mascherina con le viti.
 Fijar la tapa con los tornillos.

(Senk.-Bl. DIN 7982C, ST 3.5 x 16)
 bauseits
 incombant au client
 provided by customer
 da parte del committente
 a suministrar por el cliente

Schliess- und Arretiermöglichkeiten

Montage volet coulissant et cache

Locking and retention possibilities

Possibilità di chiusura e arresto

Montaje de dispositivos de seguridad y retención

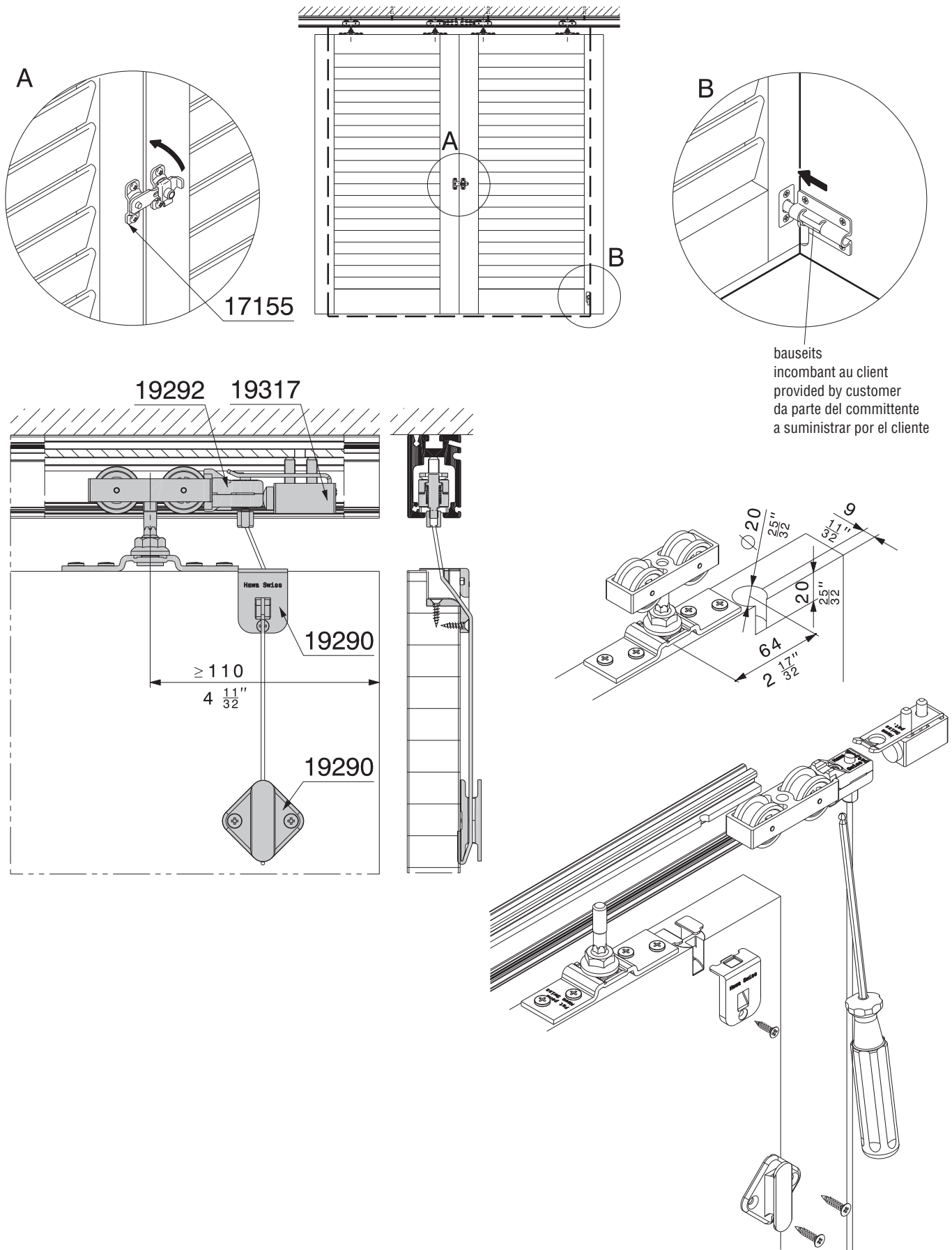

bauseits
incombant au client
provided by customer
da parte del committente
a suministrar por el cliente

Ausfräsung und Montage Stangenschloss 19592
Découpages et montage serrure à tringle 19592
Cutouts and mounting bar bolt lock 19592
Fresatura et montaggio serratura a paletto 19592
Fresado y montaje cerradura de vástago 19592

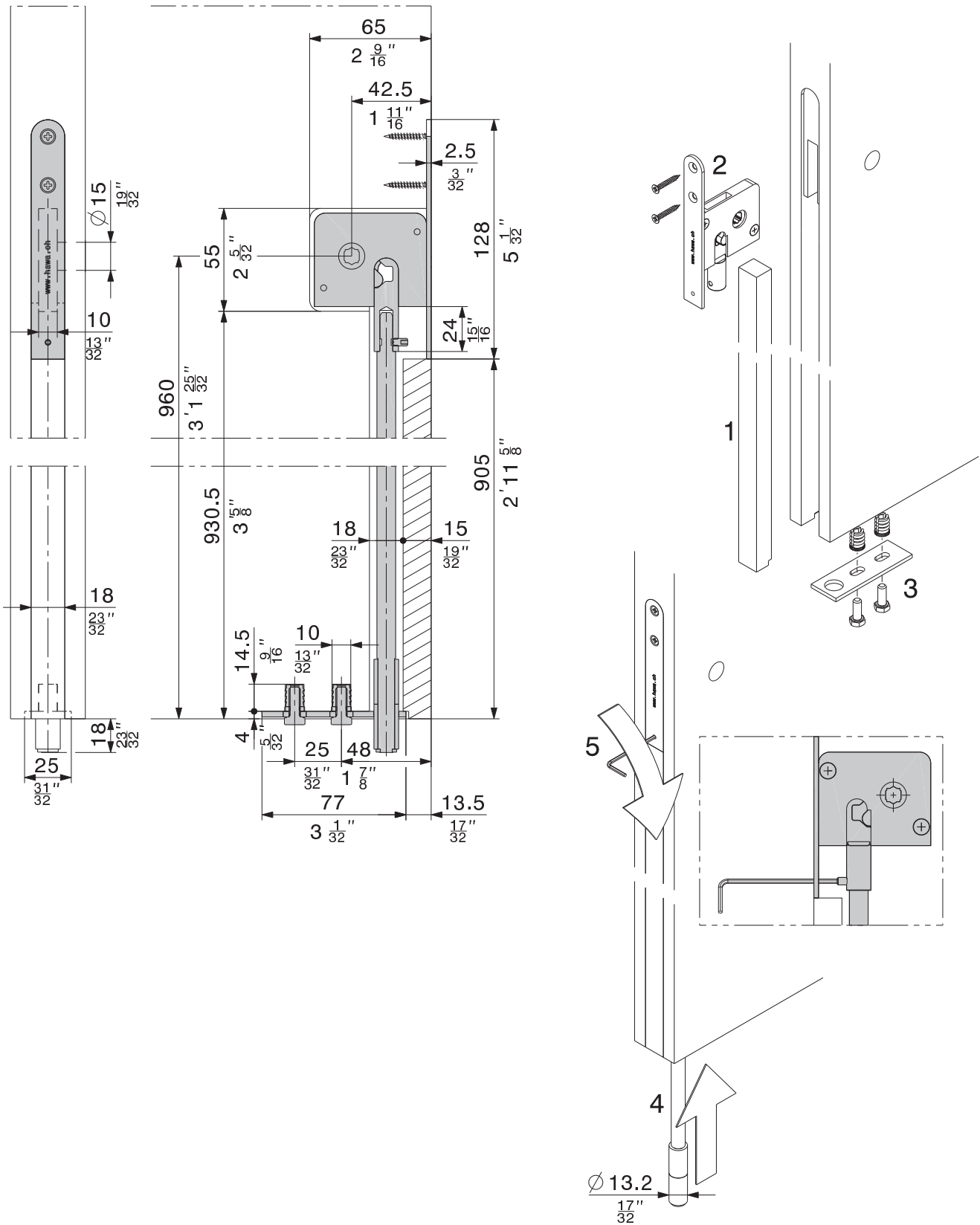



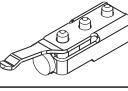
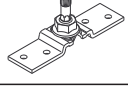
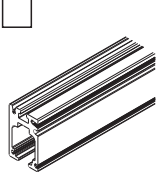
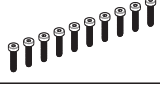
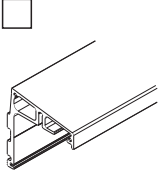
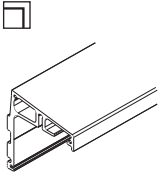
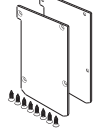

Technische Änderungen vorbehalten
 Sous réserve de modifications techniques
 Subject to modification

Con riserva di apportare modifiche tecniche
 Bajo reserva de modificaciones técnicas

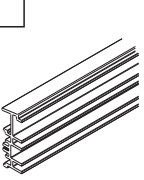
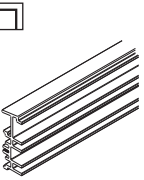
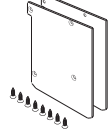
Beschlägeübersicht
Composants de la ferrure
Hardware system components
Assortimento ferramenta
Componentes de los herrajes

		17119
		17027
		17023
	2500 mm (8'2 $\frac{7}{16}$ ")	21372
	3500 mm (11'5 $\frac{13}{16}$ ")	21373
	6000 mm (19'8 $\frac{7}{32}$ ")	21374
	nach Mass sur mesure cut to size su misura a medida	21375
		21467
	2500 mm (8'2 $\frac{7}{16}$ ")	21376
	3500 mm (11'5 $\frac{13}{16}$ ")	21377
	6000 mm (19'8 $\frac{7}{32}$ ")	21378
	nach Mass sur mesure cut to size su misura a medida	21379
	6000 mm (19'8 $\frac{7}{32}$ ")	21380
	nach Mass sur mesure cut to size su misura a medida	21381
	<input type="checkbox"/>	19778
	<input type="checkbox"/>	19832
ohne Distanzprofil sans profil d'écar- tement without spacer profile senza distanziale profilato sin perfil distanciar		

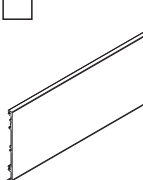
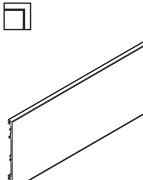
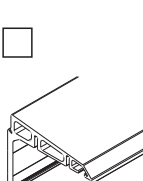
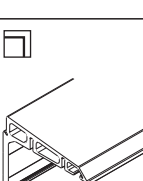
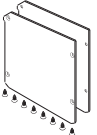
	<input type="checkbox"/>	2500 mm (8'2 $\frac{7}{16}$ ")	19726
	<input type="checkbox"/>	3500 mm (11'5 $\frac{13}{16}$ ")	19725
	<input type="checkbox"/>	6000 mm (19'8 $\frac{7}{32}$ ")	19724
		nach Mass sur mesure cut to size su misura a medida	19727
	<input type="checkbox"/>	6000 mm (19'8 $\frac{7}{32}$ ")	19738
	<input type="checkbox"/>	nach Mass sur mesure cut to size su misura a medida	19739
	<input type="checkbox"/>		19779
	<input type="checkbox"/>	mit Distanzprofil avec profil d'écar- tement with spacer profile con distanziale profilato con perfil distan- ciador	19833
			21468







	<input type="checkbox"/>	2500 mm (8'2 $\frac{7}{16}$ ")	19722
	<input type="checkbox"/>	3500 mm (11'5 $\frac{13}{16}$ ")	19721
	<input type="checkbox"/>	6000 mm (19'8 $\frac{7}{32}$ ")	19720
		nach Mass sur mesure cut to size su misura a medida	19723
	<input type="checkbox"/>	6000 mm (19'8 $\frac{7}{32}$ ")	19736
	<input type="checkbox"/>	nach Mass sur mesure cut to size su misura a medida	19737
	<input type="checkbox"/>	2500 mm (8'2 $\frac{7}{16}$ ")	21382
	<input type="checkbox"/>	3500 mm (11'5 $\frac{13}{16}$ ")	21383
	<input type="checkbox"/>	6000 mm (19'8 $\frac{7}{32}$ ")	21384
		nach Mass sur mesure cut to size su misura a medida	21385
	<input type="checkbox"/>	6000 mm (19'8 $\frac{7}{32}$ ")	21386
	<input type="checkbox"/>	nach Mass sur mesure cut to size su misura a medida	21387
	<input type="checkbox"/>		21469
	<input type="checkbox"/>		21470
			17221



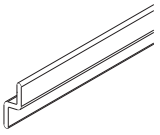
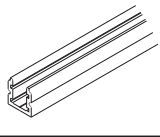
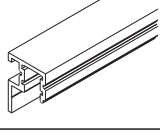

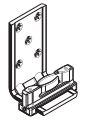

farblos eloxiert
 anodisé couleur argent
 plain anodized
 anodizzata incolore
 anodizado plata

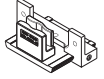
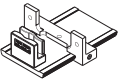
uneloxiert
 non anodisé
 unanodized
 non anodizzata
 sin anodizar

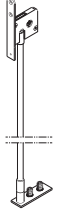
Technische Änderungen vorbehalten
 Sous réserve de modifications techniques
 Subject to modification

Con riserva di apportare modifiche tecniche
 Bajo reserva de modificaciones técnicas

<input type="checkbox"/>	6000 mm (19'8 $\frac{7}{32}$ ")	19904
	nach Mass sur mesure cut to size su misura a medida	19905
<input type="checkbox"/>	6000 mm (19'8 $\frac{7}{32}$ ")	15405
	nach Mass sur mesure cut to size su misura a medida	15554
<input type="checkbox"/>	6000 mm (19'8 $\frac{7}{32}$ ")	17049
	nach Mass sur mesure cut to size su misura a medida	17152
		15636
		20773
		15274
		15638
		14711
		16861
		19910
		19911

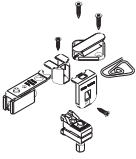
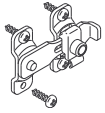
	19592
	13789
	13858
	13787
	17326
	13130
	19319
	17155

farblos eloxiert
 anodisé couleur argent
 plain anodized
 anodizzata incolore
 anodizado plata

Technische Änderungen vorbehalten
 Sous réserve de modifications techniques
 Subject to modification

Con riserva di apportare modifiche tecniche
 Bajo reserva de modificaciones técnicas